

Prinzip Beispiel

z.B. ELS V...

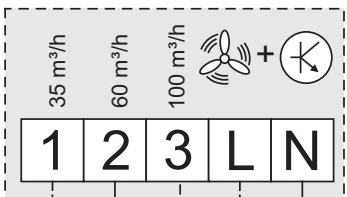

KWL 45 EM
 Art.Nr. 3012

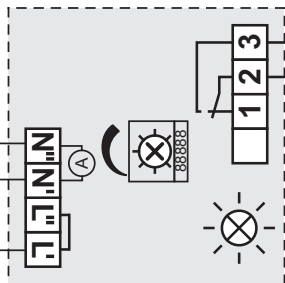

Signal

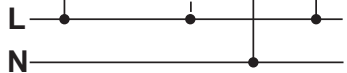

Dauer-L für Elektronik Typen mit automatischem Anlauf wie z.B. NC, P, F

Installations Beispiel mit einem KWL EC 45..

KWL EC 45



Beleuchtung

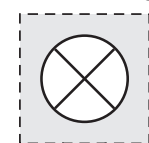

z.B. ELS V...

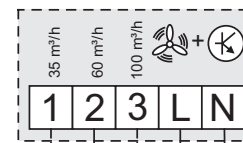

KWL 45 EM

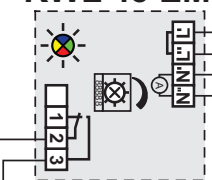

L
230 V~
N

KWL EC 45:
 Detaillierter Anschluss, siehe [SS-1091](#)

230 V~*

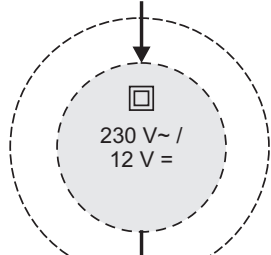

KWL 45 SNU

KWL 45 SNU

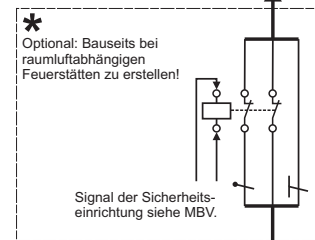

230 V~

2
 J-Y (ST) Y 0,8 mm
 max. 30 m

UP-Dose

KWL 45 BEU

Schalter

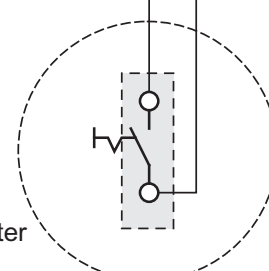

Principle Example

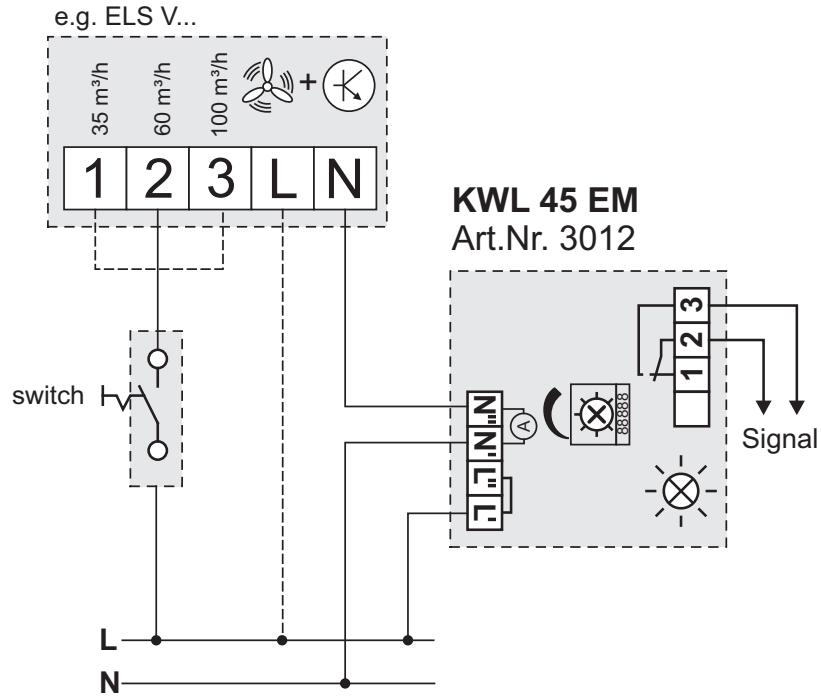

KWL 45 EM
Art.Nr. 3012

Installation example with one KWL EC 45..

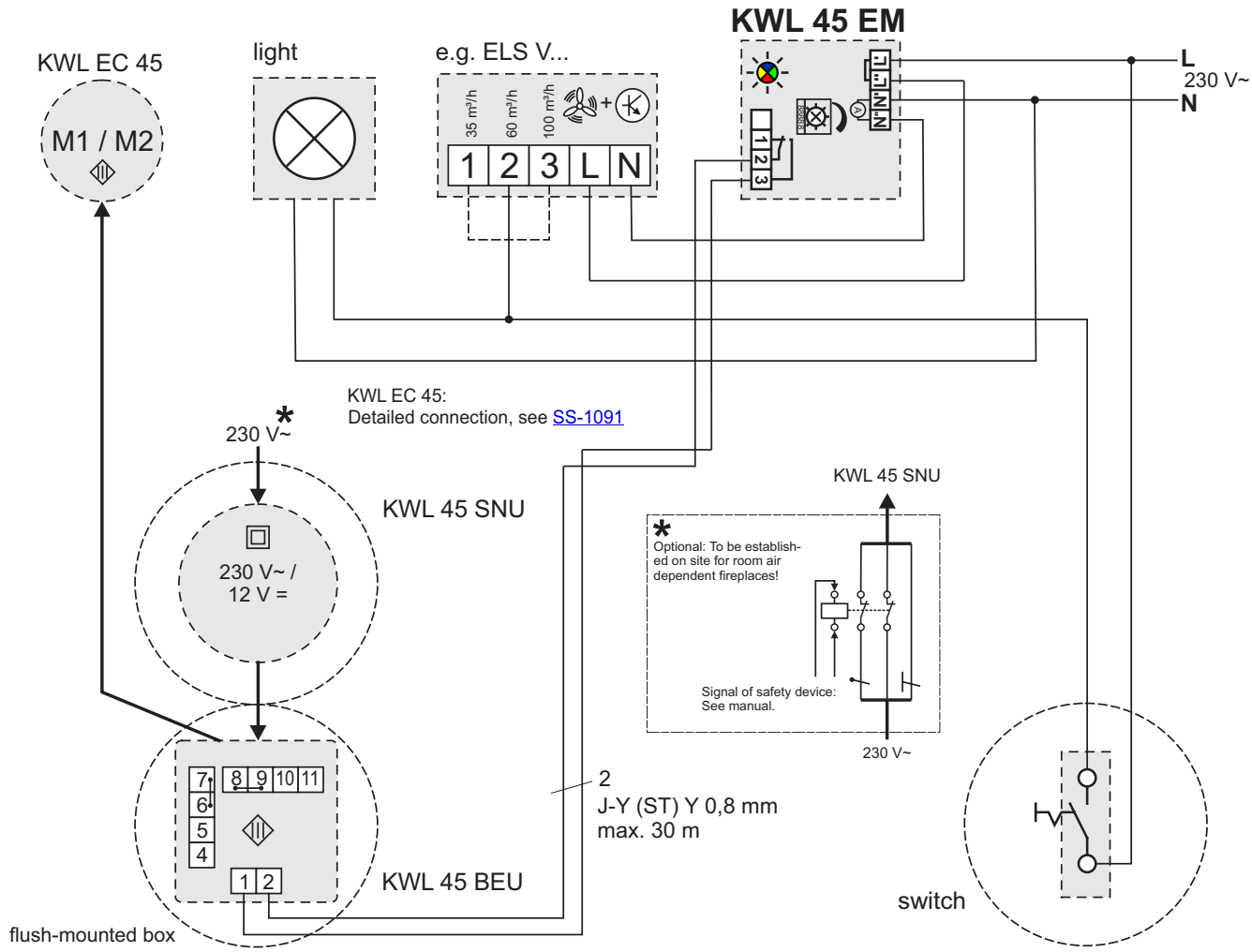

Exemple de principe

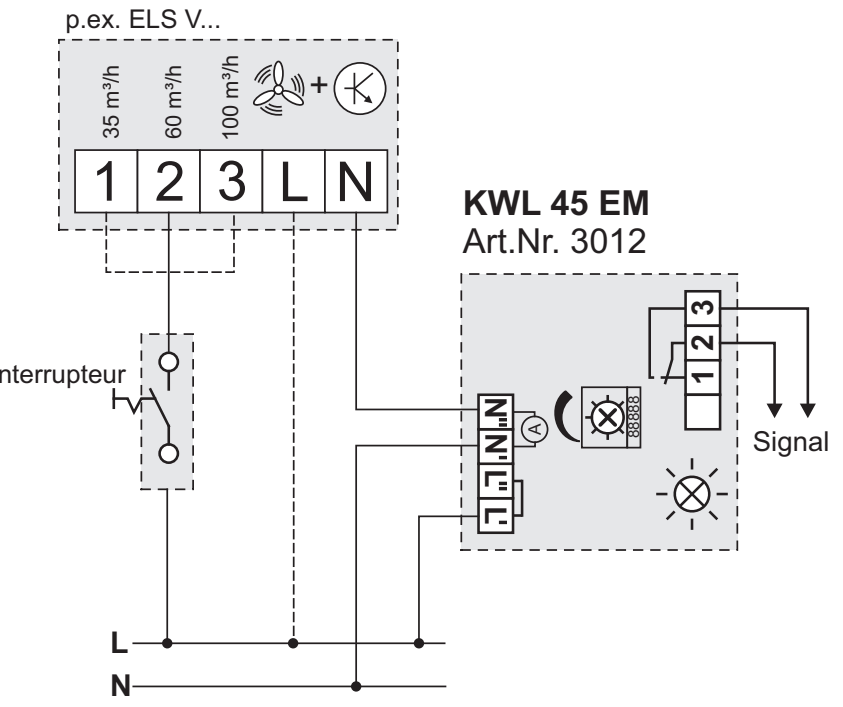

L permanent pour les types électroniques à démarrage automatique comme NC, P, F

Exemple d'installation avec un KWL EC 45..

